

# IQ SENSOR NET MIQ/CHV PLUS

VALVE MODULE FOR COMPRESSED AIR-OPERATED SENSOR CLEANING HEADS



a xylem brand



For the most recent version of the manual, please visit [www.ysi.com](http://www.ysi.com).

**Contact**

YSI  
1725 Brannum Lane  
Yellow Springs, OH 45387 USA  
Tel: +1 937-767-7241  
800-765-4974  
Email: [info@ysi.com](mailto:info@ysi.com)  
Internet: [www.ysi.com](http://www.ysi.com)

**Copyright**

© 2018 Xylem Inc.

## MIQ/CHV PLUS - List of contents

<b>1</b>	<b>Overview</b>	<b>5</b>
1.1	How to use this component operating manual	5
1.2	General characteristics	6
<b>2</b>	<b>Safety instructions</b>	<b>8</b>
2.1	Safety information	8
2.1.1	Safety information in the operating manual	8
2.1.2	Safety signs on the product	8
2.1.3	Further documents providing safety information	8
2.2	Safe operation	9
2.2.1	Authorized use	9
2.2.2	Requirements for safe operation	9
2.2.3	Unauthorized use	9
2.3	User qualification	9
<b>3</b>	<b>Installation</b>	<b>10</b>
3.1	Scope of delivery	10
3.2	Mounting for use in the IQ SENSOR NET	10
3.3	Electrical connections: General instructions	10
3.4	Connecting the valve control line	12
3.5	Connecting the compressed air hoses	14
3.6	Function check	15
<b>4</b>	<b>Settings</b>	<b>16</b>
<b>5</b>	<b>Maintenance and cleaning</b>	<b>17</b>
5.1	Maintenance	17
5.2	Cleaning	17
<b>6</b>	<b>What to do if ...</b>	<b>18</b>
<b>7</b>	<b>Technical data</b>	<b>19</b>
7.1	General data	19
7.2	MIQ/CHV PLUS	21
<b>8</b>	<b>Indexes</b>	<b>22</b>
8.1	Explanation of the messages	22
8.1.1	Error messages	22
8.1.2	Informative messages	22

**9 Accessories and options .....23**

**10 Contact Information .....24**

10.1 Ordering & Technical Support ..... 24

10.2 Service Information ..... 24

# 1 Overview

## 1.1 How to use this component operating manual

### Structure of the IQ SENSOR NET operating manual

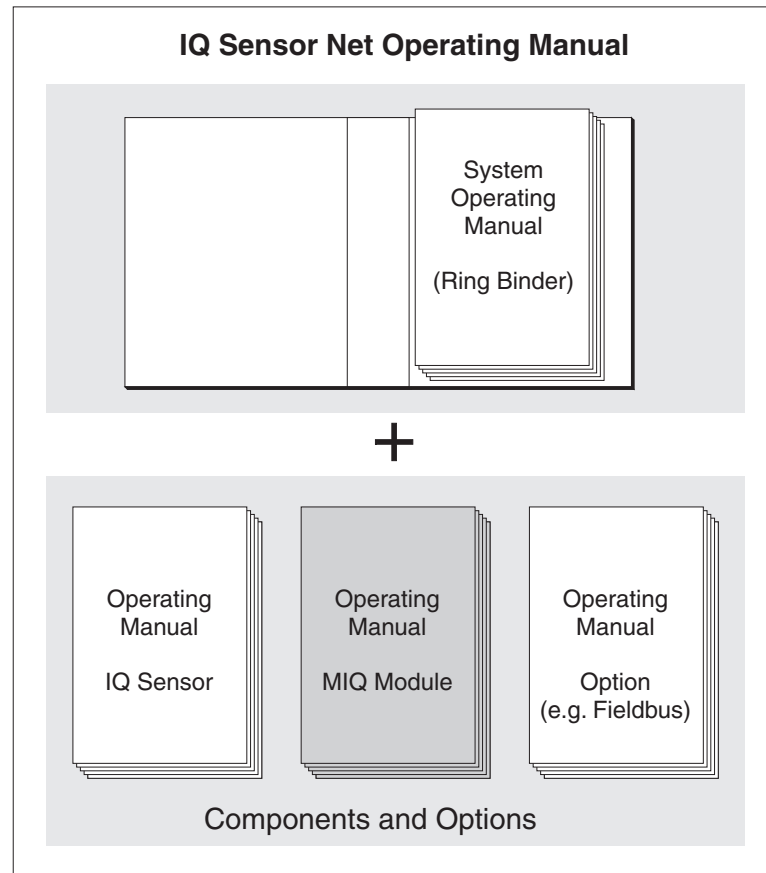

Fig. 1-1 Structure of the IQ SENSOR NET operating manual

The IQ SENSOR NET operating manual has a modular structure like the IQ SENSOR NET itself. It consists of a system operating manual and the operating manuals of all the components used.

Please file this component operating manual into the ring binder of the system operating manual.

### 1.2 General characteristics

The MIQ/CHV PLUS valve module provides a switchable compressed air valve for the operation of sensor cleaning heads.

The MIQ/CHV PLUS valve module registers on the IQ SENSOR NET system as an output (V). It appears in the list of outputs and can be linked with a sensor. Thus, the valve is controlled directly by the IQ SENSOR NET.

Alternatively, you can also control the valve via an external switch. The switch can consist of one of the following:

- any relay in the IQ SENSOR NET system
- the relay of a measuring transmitter with the R option
- any other switch (relay or sensor)

The valve module is connected with the external switch via a control line for this.

The following application example shows a cleaning system consisting of the CH cleaning head and a MIQ/CHV PLUS valve module:

#### Application example

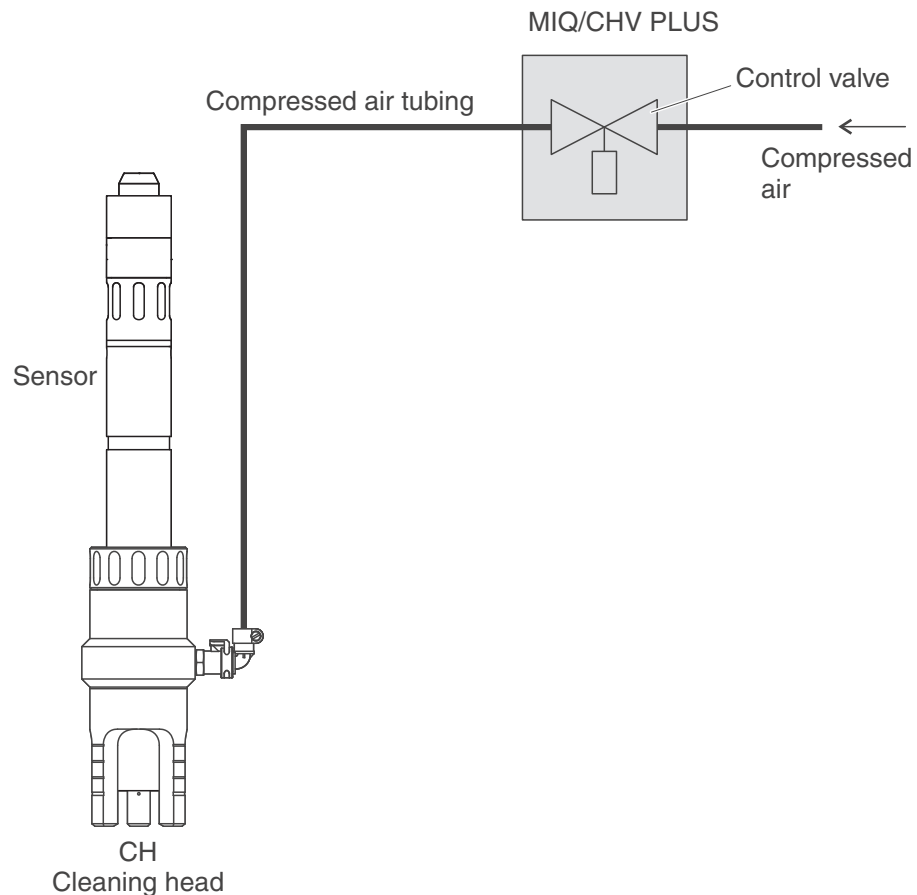

Fig. 1-2 Application example of the MIQ/CHV PLUS valve module: Power supply and control line via the IQ SENSOR NET

**Power supply** When used in the IQ SENSOR NET, the valve module is supplied with voltage by the IQ SENSOR NET.

**IQ SENSOR NET compatibility** The MIQ/CHV PLUS can be fully integrated in the IQ SENSOR NET using the MIQ standard module housing.

The housing has the same characteristics as all MIQ modules regarding stability, leakproofness and weather resistance. It also provides the same wide variety of installation options (stacked mounting, canopy mounting, top hat rail mounting, etc.).

**Terminal strip** The MIQ/CHV PLUS has the following electrical connections on the terminal strip inside the housing:

- 1 x valve circuit connection
- 2 x SENSORNET connection



If the valve is controlled via an external switch, only one SENSORNET connection can be used due to the limited number of cable glands. SENSORNET connection 1 or 2 can be selected.

## 2 Safety instructions

### 2.1 Safety information

#### 2.1.1 Safety information in the operating manual

This operating manual provides important information on the safe operation of the product. Read this operating manual thoroughly and make yourself familiar with the product before putting it into operation or working with it. The operating manual must be kept in the vicinity of the product so you can always find the information you need.

Important safety instructions are highlighted in this operating manual. They are indicated by the warning symbol (triangle) in the left column. The signal word (e.g. "CAUTION") indicates the level of danger:

**WARNING**

indicates a possibly dangerous situation that can lead to serious (irreversible) injury or death if the safety instruction is not followed.

**CAUTION**

indicates a possibly dangerous situation that can lead to slight (reversible) injury if the safety instruction is not followed.

**NOTE**

*indicates a situation where goods might be damaged if the actions mentioned are not taken.*

#### 2.1.2 Safety signs on the product

Note all labels, information signs and safety symbols on the product. A warning symbol (triangle) without text refers to safety information in this operating manual.

#### 2.1.3 Further documents providing safety information

The following documents provide additional information, which you should observe for your safety when working with the measuring system:

- Operating manuals of other components of the IQ SENSOR NET system (power supply modules, controller, accessories)
- Safety datasheets of calibration and maintenance equipment (e.g. cleaning solutions).



## 2.2 Safe operation

### 2.2.1 Authorized use

The authorized use of the MIQ/CHV PLUS consists of providing a control valve for compressed air-operated sensor cleaning heads in the IQ SENSOR NET. Only the operation according to the instructions and technical specifications given in this operating manual is authorized (see chapter 7 TECHNICAL DATA). Any other use is considered unauthorized.

### 2.2.2 Requirements for safe operation

Note the following points for safe operation:

- The product may only be operated according to the authorized use specified above.
- The product may only be operated under the environmental conditions mentioned in this operating manual.
- The product may only be supplied with power by the energy sources mentioned in this operating manual.
- The product may only be opened if this is explicitly described in this operating manual (example: connecting electrical lines to the terminal strip).

### 2.2.3 Unauthorized use

The product must not be put into operation if:

- it is visibly damaged (e.g. after being transported)
- it was stored under adverse conditions for a lengthy period of time (storing conditions, see chapter 7 TECHNICAL DATA).

## 2.3 User qualification

<b>Target group</b>	The IQ SENSOR NET system was developed for online analysis. Some maintenance activities, e.g. changing the membrane caps in D.O. sensors, require the safe handling of chemicals. Thus, we assume that the maintenance personnel is familiar with the necessary precautions to take when dealing with chemicals as a result of their professional training and experience.
<b>Special user qualifications</b>	The following installation activities may only be performed by a qualified electrician: <ul style="list-style-type: none"><li>● Connection of the MIQ/CHV PLUS to the power supply.</li><li>● Connection of external, line voltage-carrying circuits to relay contacts (see module manual of the relay output module).</li></ul>

## 3 Installation

### 3.1 Scope of delivery

The following parts are included in the scope of delivery of the MIQ/CHV PLUS:

- MIQ/CHV PLUS
- Accessory set, including:
  - 2 x screwed cable glands with seals and blind plugs
  - 2 x ISO blind nuts M4
  - 2 x cheese-head screws M4x16 with plastic washer
  - 1 x contact base
  - 2 x plastic tapping screws for fixing the contact base
  - 1 x hose clip
- Operating manual.

### 3.2 Mounting for use in the IQ SENSOR NET

The IQ SENSOR NET provides a number of options for integrating the MIQ/CHV PLUS mechanically and electrically in the system (stacked mounting, distributed mounting, etc.). The individual types of installation are described in detail in the INSTALLATION chapter of the system operating manual.

### 3.3 Electrical connections: General instructions

**Cable glands** All electric cables are fed from below via prepared openings in the enclosure of the MIQ/CHV PLUS. Cable glands with different clamping ranges are included with the MIQ/CHV PLUS to provide sealing between the cable and enclosure as well as for strain relief. Select the matching cable gland for the respective cable diameter:

- **Small**, clamping range 4.5 to 10 mm. This cable gland is suitable for all IQ SENSOR NET sensor cables.

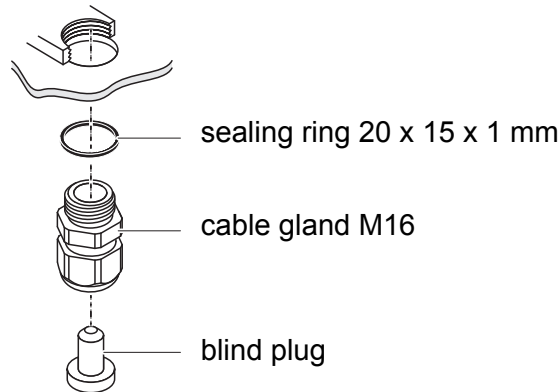

- **Large**, clamping range 7 to 13 mm. This cable gland is required for cable sheaths with an outside diameter of more than 10 mm and is screwed into the enclosure via an extension piece.

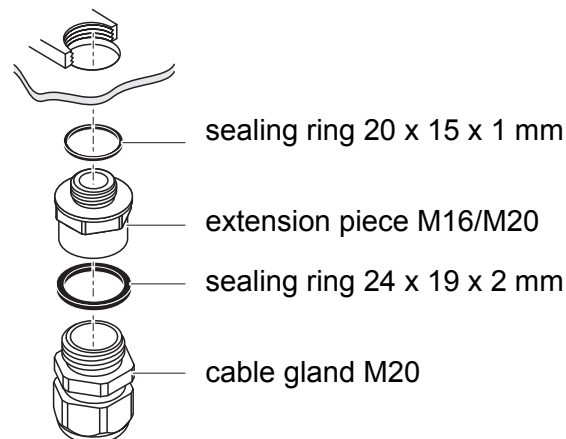

If necessary, you can order more large cable glands in a set of 4 pieces (Model EW/1, Order No. 480 051).

### General installation instructions

Observe the following points when attaching connecting wires to the terminal strip

- Shorten all wires to be used to the length required for the installation
- Always fit all the ends of the wires with wire end sleeves before connecting them to the terminal strip
- Any wires that are not used and project into the enclosure must be cut off as closely as possible to the cable gland.
- Screw a small cable gland with sealing ring into each remaining free opening and close it with a blind plug.

### 3.4 Connecting the valve control line



The valve control line must be connected if the valve is not controlled via the IQ SENSOR NET system.

#### General installation instructions

Observe the following instructions when attaching connecting wires to the terminal strip:

- Shorten all the wires used to the length required for the installation.
- Basically, fit all stranded wire ends with wire end sleeves before connecting them to the terminal strip.
- Any wires that are not used and project into the housing must be cut off as closely as possible to the cable gland.

#### Materials required

- Wire end sleeves, suitable for the connecting wires, with suitable crimping tool
- 1 x cable gland with sealing ring (scope of delivery MIQ/CHV PLUS)

#### Tools

- Cable stripping knife
- Wire stripper
- Phillips screw driver
- Small screw driver



#### WARNING

**Danger of injury from lines that are under pressure. Before opening the compressed air line, ensure that the section of line concerned is free of pressure. The compressed air glands in the housing may only be opened by a service technician authorized by YSI.**

**Connecting the control line to the terminal strip**

- 1 Open the module.

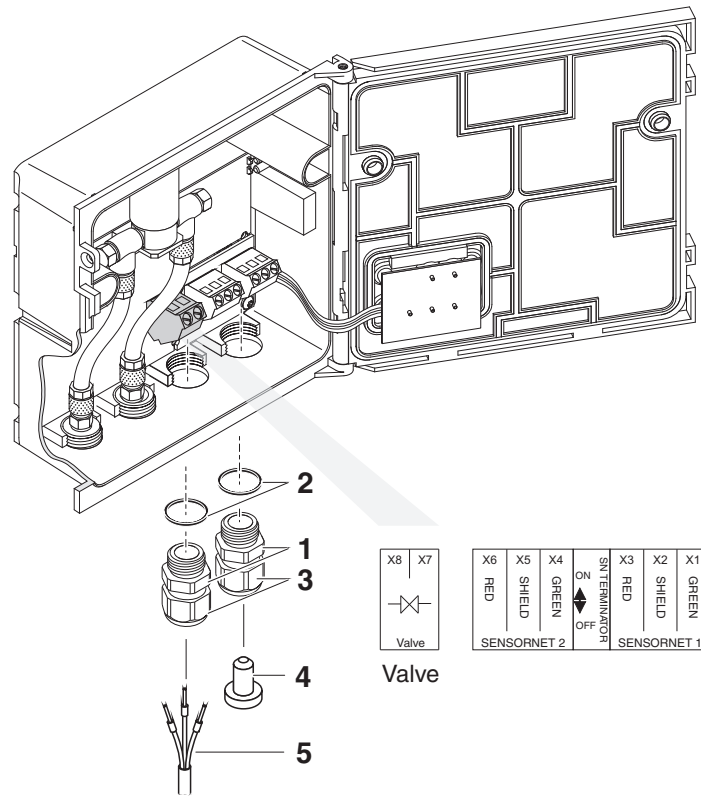

Fig. 3-1 Clamping termination for the valve control line

- 2 Screw the cable gland (pos. 1 in Fig. 3-1) with the sealing ring (pos. 2) into the left connection opening.
- 3 Loosen the coupling ring (pos. 3 in Fig. 3-1).
- 4 Feed the valve control line through the left cable gland in the module housing.
- 5 Connect the wires of the valve control line (pos. 5 in Fig. 3-1) to the clamping termination for the valve control line. While doing so, pay attention to the specifications on the label located under the terminal strip.
- 6 Tighten the coupling ring (pos. 3 in Fig. 3-1).

**WARNING**

No free wires must be allowed to project into the enclosure. Otherwise, there is a danger that areas safe to contact could come into contact with dangerous voltages. This could result in life threatening electric shock when working with the IQ SENSOR NET. Always cut off any wires that are not in use as closely as possible to the cable gland.

- 7 Close the module.
- 8 If the free opening is not used:  
Screw a cable gland with sealing ring into the free opening and close it with the enclosed blind plug (pos. 4 in Fig. 3-1).
- 9 Tighten the coupling ring (pos. 3 in Fig. 3-1).

### 3.5 Connecting the compressed air hoses

#### General instructions

Pay attention to the following instructions when connecting the compressed air hoses (they can be connected either way round):

- Follow the specification of the compressed air according to chapter 7 TECHNICAL DATA.
- Only use hoses that match the compressed air connections.
- Secure all hose connections with hose clips.

#### Open the compressed air line

Pay attention to the following instructions if you want to open the compressed air line ( e.g. during a modification):

**WARNING**

Danger of injury from lines that are under pressure. Before opening the compressed air line, ensure that the section of line concerned is free of pressure. The compressed air glands in the housing may only be opened by a service technician authorized by YSI.

### 3.6 Function check

#### General instructions

This check is also suitable for the troubleshooting of malfunctions.

If the valve is not controlled via the IQ SENSOR NET system, the valve control line must be connected.

To check that the valve triggers correctly, proceed as follows:



#### **WARNING**

**Danger of injury from lines that are under pressure. Before opening the compressed air line, ensure that the section of line concerned is free of pressure. The compressed air glands in the housing may only be opened by a service technician authorized by YSI.**

- 1 MIQ/CHV PLUS + IQ SENSOR NET:  
Put the IQ SENSOR NET system into operation.  
  
MIQ/CHV PLUS + measuring transmitter:  
Supply the power supply module with voltage and put the measuring transmitter into operation.
- 2 Adjust the cleaning intervals on the measuring system so that the valve opens.  
or  
Open the valve in the *Valve function* menu with the *Manual control* function (see system operating manual).
- 3 Check whether there is a compressed air stream on the MIQ/CHV PLUS.

## 4 Settings

The MIQ/CHV PLUS module has a valve output.

The MIQ/CHV PLUS valve module registers on the IQ SENSOR NET system as a valve output (V) and appears in the list of outputs.

On an IQ SENSOR NET terminal, you can

- assign a name to the valve output (with the 184 XT, 2020 XT, 28x and 2020 3G systems only).
- link the valve output to a sensor
- erase the link of the valve output with a sensor
- set the valve output
- check the state of the valve output

### Functions for the valve output

#### Valve output:

- *Cleaning*  
(Setting of the cleaning procedure in the menu, *Settings of outputs and links*)
- *Sensor-controlled*  
(Setting of the cleaning procedure in the menu, *Settings of sensors and diff. sensors* of the relevant sensor)
- *Manual control*



The following informations are given in the system operating manual for your IQ SENSOR NET system:

- general operating principles
- settings for the valve outputs



## **5 Maintenance and cleaning**

### **5.1 Maintenance**

The MIQ/CHV PLUS requires no special maintenance.

### **5.2 Cleaning**

The cleaning of IQ SENSOR NET components is described in the IQ SENSOR NET system operating manual.

## 6 What to do if ...

No compressed air at the output	Cause	Remedy
	– Compressed air supply interrupted or too weak	– Check the compressed air supply
	– Supply voltage not present or too low	<u>IQ SENSOR NET:</u> – See the chapter, WHAT TO DO IF... in the system manual
	– Error in triggering	– Perform the function check according to section 3.6. – If the valve does not switch, check the control <ul style="list-style-type: none"> <li>– loose clamping connection</li> <li>– broken control line</li> <li>– defective relay output</li> <li>– valve output was not linked with a sensor (see system operating manual)</li> <li>– incorrect setting of the linked valve output (see chapter 4)</li> </ul>

## 7 Technical data

### 7.1 General data

#### Dimensions

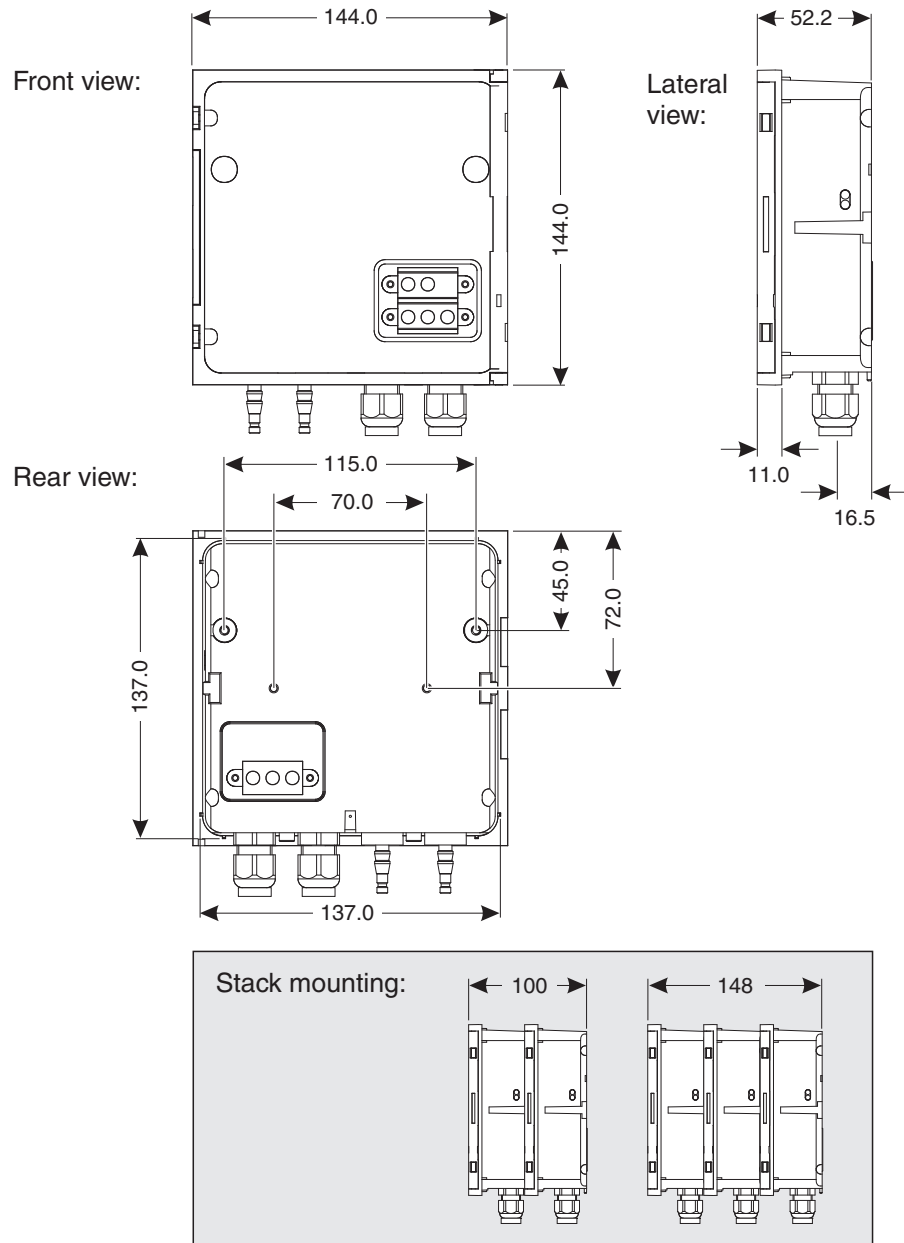

Fig. 7-1 Dimension drawing of the MIQ/CHV PLUS (dimensions in mm)

<b>Mechanical construction</b>	Maximum number of modules in a module stack	3 (plus a terminal component in the IQ SENSOR NET)
	Materials	<ul style="list-style-type: none"> <li>– Housing: Polycarbonate with 20 % glass fiber</li> <li>– Pressure hose sleeves: POM</li> </ul>

Weight	Approx. 0.5 kg
Type of protection	IP 66 (not suitable for conduit connection)

**Ambient conditions**

<b>Temperature</b>	
Operation	0 °C ... + 55 °C (32 ... 131 °F)
Storage	- 25 °C ... + 65 °C (-13 ... 149 °F)

<b>Relative humidity</b>	
Yearly average	≤ 90 %
Dew formation	Possible

**Meter safety**

Applicable norms	<ul style="list-style-type: none"> <li>- EN 61010-1</li> <li>- UL 61010-1</li> <li>- CAN/CSA C22.2#61010-1</li> </ul>
------------------	---

**EMC product and system characteristics**

EN 61326	<p>EMC requirements for electrical resources for control technology and laboratory use</p> <ul style="list-style-type: none"> <li>- Resources for industrial areas, intended for indispensable operation</li> <li>- Interference emission limits for resources of class A</li> </ul>
System lightning protection	Noticeably extended qualitative and quantitative protective characteristics as opposed to EN 61326
FCC, class A	

## 7.2 MIQ/CHV PLUS

<b>Electrical data</b>	Nominal voltage	Max. 24 VDC via a separate power supply module. <u>IQ SENSOR NET:</u> For details, see chapter TECHNICAL DATA of the IQ SENSOR NET system operating manual  Suitable power supply modules: – MIQ/PS – MIQ/24V
	Power consumption	Approx. 2,5 W
	Protective class	III
<b>Terminal connections</b>	IQ SENSOR NET connections	2 Additional connectable SENSORNET terminator (terminating resistor)  <u>Note:</u> If the valve is controlled via an external switch, only one SENSORNET connection can be used due to the limited number of cable glands. SENSORNET connection 1 or 2 can be selected.
	Valve switching contact	1
	Terminal type	Screw-type terminal strip, accessible by opening the lid
	Terminal ranges	Solid wires: 0.2 ... 4.0 mm <sup>2</sup> AWG 24 ... 12 Flexible wires: 0.2 ... 2.5 mm <sup>2</sup>
	Cable feeds	Cable glands M16 x 1.5 on the underside of the module
<b>Valve circuits</b>	Switching voltage	Approx. 12 V
	Max. switching current	Approx. 70 mA
<b>Compressed air</b>	Required air quality	Dry, dust-free and oil-free
	Operating pressure	Max. 5 x 10 <sup>5</sup> Pa (5 bar) absolute
	Connections	6 mm hose nozzles

## 8 Indexes

### 8.1 Explanation of the messages

In this chapter you will find a list with all the message codes and corresponding message texts that may occur in the log book of the IQ SENSOR NET system for the MIQ/CHV PLUS output module.



Information about

- Contents and structure of the log book and
- Structure of the message code

can be found in the LOG BOOK chapter of the IQ SENSOR NET system operating manual.

All message codes of the MIQ/CHV PLUS output module end with the number, "432".

#### 8.1.1 Error messages

<b>Message code</b>	<b>Message text</b>
EI2432	<p><i>Operational voltage too low, no operation possible</i></p> <p><i>* Check installation and cable lengths, Follow installation instructions</i></p> <p><i>* Power unit(s) overloaded, add power unit(s)</i></p> <p><i>* Defective components, replace components</i></p> <p><i>* Defective components, replace components</i></p>

#### 8.1.2 Informative messages

The MIQ/CHV PLUS output module does not send any informative messages.

## 9 Accessories and options

Description	Model	Order no.
Cleaning head for online sensors with 40 mm diameter	CH	900 107Y
Tubing set, comprising: <ul style="list-style-type: none"> <li>– 15 m compressed-air hose</li> <li>– 1 quick disconnect coupler, complete</li> <li>– 2 hose clips</li> <li>– Teflon tape</li> </ul>	CH/Epack	900 111Y
Long-range power supply for 100-240 VAC nominal input voltage	MIQ/PS	480 004Y
Power supply for 24 V AC/DC nominal input voltage	MIQ/24V	480 006Y
IQ SENSOR NET cable - please specify required length in m when ordering	SNCIQ	480 046Y
	SNCIQ/UG	480 047Y
Sun shield for a unit of up to three stacked MIQ modules	SSH/IQ	109 295Y
Sun shield for a unit of up to two stacked MIQ modules	SD/K 170	109 284Y
Mounting kit for fixing the SD/K 170 sun shield on horizontal or vertical pipes	MR/SD 170	109 286Y
Kit for wall mounting of a MIQ module	WMS/IQ	480 052Y
Set for panel mounting of MIQ modules; Panel aperture 138 x 138 mm according to DIN 43700 or IEC 473	PMS/IQ	480 048Y
Set for mounting of MIQ modules on a 35 mm top hat rail according to EN 50022	THS/IQ	480 050Y

## 10 Contact Information

### 10.1 Ordering & Technical Support

Telephone: (800) 897-4151  
(937) 767-7241  
Monday through Friday, 8:00 AM to 5:00 PM ET

Fax: (937) 767-1058

Email: [info@ysi.com](mailto:info@ysi.com)

Mail: YSI Incorporated  
1725 Brannum Lane  
Yellow Springs, OH 45387  
USA

Internet: [www.ysi.com](http://www.ysi.com)

When placing an order please have the following information available:

YSI account number (if available)	Name and Phone Number
Model number or brief description	Billing and shipping address
Quantity	Purchase Order or Credit Card

### 10.2 Service Information

YSI has authorized service centers throughout the United States and Internationally. For the nearest service center information, please visit [www.ysi.com](http://www.ysi.com) and click 'Support' or contact YSI Technical Support directly at 800-897-4151.

When returning a product for service, include the Product Return form with cleaning certification. The form must be completely filled out for an YSI Service Center to accept the instrument for service. The Product Return form may be downloaded at [www.ysi.com](http://www.ysi.com) and clicking on the 'Support' tab.





# Xylem |'zīləm|

- 1) The tissue in plants that brings water upward from the roots;
- 2) a leading global water technology company.

We're 12,500 people unified in a common purpose: creating innovative solutions to meet our world's water needs. Developing new technologies that will improve the way water is used, conserved, and re-used in the future is central to our work. We move, treat, analyze, and return water to the environment, and we help people use water efficiently, in their homes, buildings, factories and farms. In more than 150 countries, we have strong, long-standing relationships with customers who know us for our powerful combination of leading product brands and applications expertise, backed by a legacy of innovation.

**For more information on how Xylem can help you, go to [www.xylem.com](http://www.xylem.com)**



a **xylem** brand

YSI  
1725 Brannum Lane  
Yellow Springs, OH 45387  
Tel: +1 937-767-7241; 800-765-4974  
Fax: +1 937-767-1058  
Email: [info@ysi.com](mailto:info@ysi.com)  
Web: [www.ysi.com](http://www.ysi.com)

©Xylem Inc